



A. Uberti S.p.A.

Via Artigiani, 1 - Gardone V.T. (Brescia) - ITALY

## Instruction Manual

BEFORE REMOVING THE FIREARM FROM THIS PACKAGE,  
READ & UNDERSTAND THE PRECAUTIONS IN THE  
INSTRUCTIONS MANUAL

### 1885 SINGLE SHOT

#### SPECIAL SAFETY INSTRUCTIONS

**CAUTION:** Use only Factory loaded ammunition. Do not use reloaded or hand-loaded ammunition.

- Always use only good condition, undamaged, clean, dry, original high quality, commercially manufactured ammunition of a reputable company which is appropriate to the gun's caliber. Ammunition which is too small can fall forward and become a barrel obstruction. Manufacturers design guns and ammunition within exacting engineering safety limits. Since handloads are often outside those limits, they are not to be used.

**WARNING:** When a round is in the chamber, and regardless of the safety devices, this gun may discharge accidentally if it is dropped or receives a blow. Do not put a round in the chamber until the gun is in your hand and you are ready to shoot. Clear the gun immediately after shooting.

Use **ONLY COMMERCIAL** loaded cartridges that have been loaded in accordance with SAAMI-C.I.P. standards.

To load the firearm:

1) To load your 1885 Rifle swing down the loading lever and push it forcefully forward to lower the breech block. (Photo n. 1)

2) Always keep the muzzle of your rifle pointing in a safe direction, even when you are certain that the rifle is not loaded.

Absolutely, never point the firearm towards anything you do not intend to shoot.

To load your Rifle, hold your gun with the muzzle pointing to the ground at an angle of approximately 30° (Photo nr. 2) making sure that the muzzle does not touch the ground or is in any way obstructed by anything. Insert a cartridge into the chamber.

3) Make sure the cartridge is fully inserted into the chamber to avoid interference with the bolt as it closes (Photo nr. 3).



4) Always point the gun in a safe direction. You can now close the lever completely. At this point your rifle is in the safety position or "half cock position" (Photo nr. 4)

5) Your rifle is now in "half cock position" or "safety position" (Photo nr. 5).

YOUR RIFLE HAS A "HALF COCK" SAFETY DEVICE, however, NEVER RELY TOTALLY ON ANY SAFETY DEVICE. A safety device, like any mechanical device could sometimes fail or it could be worn or inadvertently manipulated into an unsafe condition. ALWAYS TREAT YOUR RIFLE AS IF IT WAS LOADED AND READY TO FIRE.



#### FIRING

**CAUTION:** Make sure you have read and are thoroughly familiar with all safety instructions above before firing.

#### CAUTION:

- Always wear and encourage others near you to wear proper ear protection when shooting, especially on a range, since the noise from your gun and other guns close to you could result in

N.	COD. NO.	Q.ty	PART
1	0870001	1	FRAME
2	0870002	1	HAMMER
3	0880003	1	BARREL 30" .45/70
10	0870010	1	TRIGGER
15	0202015	1	SIGHT
19	0870019	1	TRIGGER SPRING
20	0870020	1	MAIN SPRING
26	0870026	1	TRIGGERGUARD
35	0870035	1	TRIGGER SPRING SCREW
55	0242055	1	REAR
57	0880057	1	BUTT STOCK
58	0880058	1	BUTT PLATE
61	0242061	1	REAR SIGHT WINDAGE
62	0200062	3	BUTT PLATE SCREW
63	0870063	1	TANG SCREW
68	0880068	1	FOREND
79	0870079	1	EXTRACTOR .45/70
79	0870079G	1	ROLIGH EXTRACTOR
89	0870089	1	LEVER
92	0870092	1	RIGHT LEVER SPRING
95	0870095	1	FIRING PIN SPRING
97	0870097	1	BRECH BLOCK
98	0870098	1	FIRING PIN
99	0870099	2	TRIGGER PIN
101	0870101	1	LEVEL PIN SCREW
107	0870107	1	LEVER PIN
119	0242119	2	REAR SCREW
124	0870035	1	LEVER SPRING SCREW
129	0870129	1	FIRING PIN BEARING
167	0870167	2	TRIGGERGUARD SCREW
172	0130172	1	FOREND CAP
174	0870174	1	SEAR
175	0870175	1	SEAR SPRING
177	0870177	1	BLOCK PIN
178	0870178	1	HAMMER PIN

N.	COD. NO.	Q.ty	PART
179	0870179	1	SEAR PIN
182	0870182	1	TENON
183	0870183	1	FOREND SCREW
217	0880217	1	BUTT PLATE GATE
230	0870230	1	BUTT PLATE GATE PIN
231	0880231	1	BUTT PLATE GATE SPRING
232	0880232	1	BUTT PLATE GATE SCREW
245	0870245	1	BUSHING
294	0870294	1	KNOCK OFF
363	0870363	1	SEAR SPRING SCREW
449	0870449	1	LINK PIN
617	0870617	1	LINK
661	0870661	2	FIRING PIN BEARING SCREW
662	0870662	1	LEVER SPRING TENON
<b>ALTERNATIVES</b>			
79	0871079	1	EXTRACTOR 30/30 - 38/55
79	0872079	1	EXTRACTOR 45LC - 44/40 - 44SP - 38/40
<b>RIFLE ALTERNATIVES</b>			
3	0881003	1	BARREL 30" .30-30
3	0882003	1	BARREL 30" .30 .45 LC
3	0883003	1	BARREL 30" .44-40
3	0884003	1	BARREL 30" .40-65
3	0891003	1	BARREL 32" .45-70
3	0892003	1	BARREKL 32" .40-65
<b>CARBINE ALTERNATIVES</b>			
3	0870003	1	BARREL 28" .45-70
3	0871003	1	BARREL 28" .30-30
3	0872003	1	BARREL 28" .30 .45 LC
3	0873003	1	BARREL 28" .45LC
3	0874003	1	BARREL 28" .44-40
3	0874003	1	BARREL 28" .40-65
57	0870057	1	BUTT STOCK
58	0870058	1	BUTT PLATE
68	0870068	1	FOREND
217	0870217	1	BUTT PLATE GATE
231	0870231	1	BUTT PLATE GATE SPRING

#### RIFLE HIGH-WALL MOD.

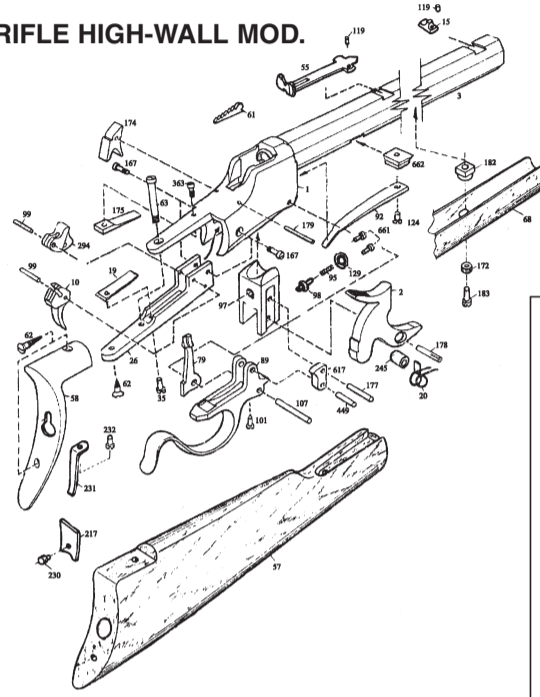

#### CARBINE MOD.

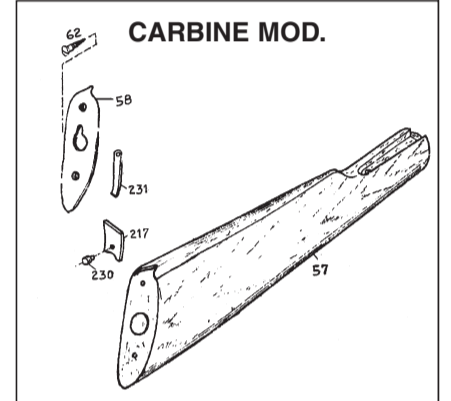

a humming or ringing sound in an exposed ear for some time after rifting. Repeated exposure to shooting noise could result in permanent hearing loss.

- Always wear protective shooting glasses to protect your eyes from injury by gun powder, gas, lubricant, dirt or metallic particles, carbon residue, sparks or other debris.

To fire:

- Be sure you are familiar with the "safety instructions".
- Keep gun pointing in a safe direction.
- Always use extreme care with a misfire or failure to fire. Keep the gun pointed in a safe direction and wait one full minute. This is because if hangfire or slow ignition has occurred, the round will still fire. If the round fails to fire after waiting, eject the round and examine the primer. Immediately refer to a competent gunsmith if you notice the firing pin indent on the primer is light, off-center, or does not exist.

6) You can now point your gun at the intended target.

Only when you are sure that you are pointing at your target and that nobody is anywhere near the target, behind it or anywhere next to you, you can cock your hammer to the full cock position. During this operation, make sure that you don't touch the trigger in anyway. Only when you are absolutely certain that you are ready to shoot, you can pull the trigger (Photo nr. 6).

#### UNLOADING

**CAUTION:** Make sure you have read and are thoroughly familiar with all safety instructions above before unloading.

**CAUTION:** Immediately after use and before cleaning, unload your gun.

To unload:

- Keep gun pointing in a safe direction, keep fingers off trigger and always keep hands and face away from muzzle and ejection port.
- To unload your rifle or to remove a cartridge, make sure you are keeping your muzzle pointing in a safe direction, swing down the lever until the cartridge is ejected. The cartridge will not be fully ejected and you will have to remove it manually, once the ejector has removed it (Photo nr. 7)

**CAUTION:** Look in the chamber to ensure it is empty.

#### SET TRIGGER MODEL

PAY ATTENTION before you load the gun, make sure it is pointed in a safe direction.

As soon as the trigger is loaded, it is very sensitive and the shot can be fired unexpectedly.

#### STORAGE

**CAUTION:** Always store your gun unloaded and separate from ammunition, each in its own locked receptacle beyond children's reach and sight.

