

INSTRUCTION MANUAL



SPENCER



OFFICIAL SPONSOR



ATTENTION: BEFORE REMOVING THIS FIREARM FROM ITS PACKAGE READ & UNDERSTAND WARNINGS, INSTRUCTIONS AND PRECAUTIONS IN THIS USER'S MANUAL

INDEX

WARNINGS	3
SAFETY RULES	4
IDENTIFYING MARKINGS.....	6
MODEL RANGE	5
AMMUNITION	6
SPENCER MODEL – AMMUNITION WARNING	7
LOADING	8
FIRING	9
UNLOADING.....	9
DISASSEMBLY	10
MALFUNCTION	11
CLEANING	11
EXPLODED VIEW	12
PARTS LIST	13
WARRANTY CONDITIONS.....	20

WARNINGS

The manufacturer is not responsible for damage to objects caused by misuse of the gun or for injuries to persons or animals, or in case of death, caused voluntarily or involuntarily by the gun user.

The manufacturer is not responsible for injuries caused by poor maintenance, misuse of the gun, unauthorized or improper modifications.

The manufacturer declines responsibility for the indirect consequences of any injuries and / or death of persons or animals, damage to objects caused by use of the gun or by primer explosion, by bullet's ricochet, or unsafe loading practices and / or procedure.

Read the entire manual and learn the proper use of the gun without live ammunition. It is important that you understand the proper use of this product.

The life of the people close to you may depend on your safe behaviour.

If the manual is not clear, please contact the dealer where you bought the gun or call the distributor or the manufacturer by using the contact information provided within this manual.

The manufacturer declines any responsibility for misuse of the firearm. In case of alteration of the firearm, The manufacturer declines any civil and penal responsibility and will not refund any damage.

QUALITY INSPECTION: Every firearm is thoroughly inspected by the manufacturer, for function and cosmetic blemish, prior to shipment.

To guarantee the gun is safe, all guns produced in the Italian facility are sent to the National Proof House of Gardone Val Trompia – BRESCIA – ITALY for proof testing, in compliance with Italian law. The Proof House tests the firearm with heavy loads then checks the barrel, chamber and headspace to make certain the firearm is safe for use with standard factory ammunition. The National Proof House will put their markings on the gun, certifying the gun is qualified and can be sold.

Guns produced in our US facility are scrupulously tested in our premises.

Warning!

Discharging firearms in poorly ventilated areas, cleaning firearms, or handling ammunition may result in exposure to lead or other substances known to the State of California to cause birth defects, reproductive harm, and other serious physical injury. Have adequate ventilation at all times. Wash hands thoroughly after exposure.

ANY LEGAL DISPUTE WILL BE UNDER THE JURISDICTION OF A COURT IN THE STATE OF OHIO – USA, OR IN THE COURT OF BRESCIA – ITALY, AT OUR DISCRETION.

SAFETY RULES

1. Read the instructions carefully before use. Reading the manual and careful examination of the gun are fundamental to avoid any kind of problem.
2. Be aware that you are handling a firearm; therefore your knowledge and behaviour may affect your life and those of the people close to you.
3. Guns and ammunitions must be kept in separate places.
4. ALWAYS keep guns and ammunitions out of reach of children.
5. Store the gun in a clean, dry and airy place after use to avoid rust in mechanical parts that may cause serious problems in functioning after a period of inactivity.
6. The gun must ALWAYS be stored unloaded, ALWAYS check that the chamber is empty.
7. Keep away from open flame or heating sources.
8. Never leave a loaded gun unattended.
9. Never leave the weapon loaded, it could fall and cause injury and death. Always point the gun in a safe direction, and handle it as though it were loaded. This is especially important when loading and unloading the gun, and when handing it to someone else. Never take someone's word that it is unloaded. Always make sure the gun is unloaded before laying it down or handing it to someone else.
10. After use, clean and lubricate the inside of the barrel with appropriate oil. Grease or oil build up can cause excessive pressure and result in serious personal injuries. Before using the gun again, inspect the barrel and chamber to make certain that there are no obstructions in the bore. Remove any oil residue with rod and dry patch before shooting.
11. Accumulation of rust in the barrel can cause excessive pressures resulting in serious injury and may cause the explosion of the barrel. A rusted, pitted or eroded barrel should be replaced.
12. Before shooting ALWAYS check to ensure that the barrel is free of obstructions.
13. Never force a jammed action, this act could cause explosion of the round and consequent injury.
14. Use exclusively factory loaded ammunition of the caliber specified on the firearm barrel. Use of different calibers may cause serious personal injuries to you and to people close to you.
15. In case of misfire, manually extract the cartridge from the chamber. If firearm fails to fire when trigger is pulled, as a result of slow primer ignition (hangfire), keep muzzle pointed downrange for a minimum of 30 seconds. If the round does not fire, remove the magazine, clear the weapon and examine the ejected, unfired cartridge. If the indent from the firing pin is off center, light or absent, take the gun to a competent gunsmith. If the indent appears normal compared to other rounds, assume a faulty round, separate from other cartridges, reload and continue shooting.
16. Do not attempt to re-use unexploded ammunitions.
17. NEVER modify any parts of your gun. Any alteration may cause serious personal injury and voids the warranty.
18. Only a qualified gunsmith may service the gun for repair or serious maintenance.
19. Pay great attention during transportation and use. Mechanical safety devices can fail. Developing intelligent, good safety habits is the best way to prevent accidents.
20. Never rest your finger on the trigger until the very moment you wish to shoot. Always keep the safety on until you are ready to safely shoot at an intended target (see safety features).
Note: Safety devices on guns are extras and are not a substitute for your proper and safe handling practices.
21. ALWAYS keep the gun unloaded when transporting it from home to the shooting areas. Carefully check that cartridge chamber is empty.
22. When you walk around with the gun in a shooting area, ALWAYS keep the muzzle pointed in a safe direction.
23. NEVER run with a loaded gun, don't cross any obstacle (fences or water courses, etc.) or walk where there is any possibility of slipping or falling without having your firearm unloaded and in safety position.
24. When selecting a place to shoot, always be absolutely sure of your target and the area behind it before you touch the trigger, making sure there is an adequate backstop which

will stop and contain bullets. A bullet can travel through or past your target with a range up to 1 1/2 miles. If you have any doubt, do not shoot.

25. Never shoot against a solid surface or in a pool of water, the projectiles could ricochet and shoot toward any direction. Don't shoot up into the sky.
26. Keep all bystanders behind you, standing beside a shooter is not a safe position. Make sure all other shooters and bystanders are well away from the ejection port.
27. Do not smoke while handling, loading or shooting any ammunition, especially black powder. Keep black powder in a closed container at all times, reclosing the container after each and every use.
28. Never drink alcoholic beverages or take any drugs before or during shooting, as this not only constitutes criminal disregard for your safety and that of others, but will seriously impair your judgment and vision. Never use a gun while you are taking medication unless you have checked with your doctor to ensure your fitness to handle the gun safely.
29. Always wear and encourage others near you to wear proper ear protection when shooting, especially on a range since the noise from your gun, and other guns close to you, could result in permanent hearing loss.
30. Always wear protective shooting glasses to protect your eyes from injury by gun powder, gas, lubricant, dirt or metallic particles, carbon residue, sparks or other debris.
31. Wash hands thoroughly after shooting and handling firearms to remove any unwanted residues.
32. NEVER leave the loaded firearm or the loaded magazine in the sun
33. By replica firearms there is no modern safety. In this case you must pay even more attention to safety rules.

REMEMBER: No mechanical safety device is infallible.

The user is responsible for injuries or damages caused to him or to other persons.

COMPLETE KNOWLEDGE OF YOUR FIREARM CAN MAKE THE DIFFERENCE.

MODEL RANGE

CODE	DESCRIPTION	Caliber	Barrel length IN	Total length IN	Grooves	Twist rate	Weight LBS	Barrel Type	Shots
920.021	1860 SPENCER Carbine 56/50 20" rnd-CC	56/50 Spencer	22"	37"	6	1 X 24 in	9	Round	7
920.023	1860 SPENCER Carbine .45Schofield 20" CC	.45 Schofield	22"	37"	6	1 X 20 in	9	Round	7
920.061	1860 SPENCER Rifle 56/50 30" 3 BANDS, CC	56/50	30"	47"	6	1 X 24 in	10.6	Octag	7
920.062	1860 SPENCER Carbine .44/40 win 20" CC	.44/40Win	22"	37"	6	1 X 36 in	9	Round	7
920.081	1860 SPENCER Rifle 44/40 30" 3 BANDS, CC	.44/40Win	30"	47"	6	1 X 36 in	10.6	Octagonal	7
920.084	1860 SPENCER Carbine ..45LC 20" rnd-CC	.45LC	22"	37"	6	1 X 16 in	9	Round	7
920.085	1860 SPENCER Rifle .45LC 30" 3 BANDS, CC	.45LC	30"	47"	6	1 X 16 in	10.6	Octagonal	7

IDENTIFYING MARKINGS

Every gun we produce has a serial number that is marked on the receiver/frame. Close to the serial number you will also find the manufacturers information with the model name and caliber marked either on the frame or the slide as required by law.

These markings must not be removed from the firearm for any reason.

AMMUNITION

NOTICE

WE SPECIFICALLY DISCLAIM RESPONSIBILITY FOR ANY DAMAGE OR INJURY WHATSOEVER OCCURRING IN CONNECTION WITH, OR AS THE RESULT OF, THE USE OF FAULTY, OR NONSTANDARD, OR "REMANUFACTURED" OR HANDLOADED (RELOADED) AMMUNITION, OR OF CARTRIDGES OTHER THAN THOSE FOR WHICH THE FIREARM WAS ORIGINALLY CHAMBERED.

- Death, serious injury, and damage can result from the use of wrong ammunition, bore obstructions, powder overloads, or incorrect cartridge components.
- Use only ammunition specifically recommended for your firearm (the caliber is specified on the barrel/cylinder/frame).
- Always use cartridges whose length is equal or inferior to that indicated on the barrel.
- Use only high quality, original factory manufactured ammunition whose pressure cannot be higher than the one stated by S.A.A.M.I. or C.I.P. Do not use ammunition that is questionable in identity or with an absent or unclear stamp.
- Your gun has been designed for ammunition of a specific caliber – do not alter the barrel, chamber, caliber for which your gun was designed.
- Be sure you never mix ammunition.
- Firearms may be severely damaged, and serious injury to the shooter or others may result from any condition causing excessive pressure inside the chamber or barrel during firing. Excessive pressure can be caused by obstruction in the barrel, propellant powder overloads, or by the use of incorrect or defectively assembled cartridges. In addition, the use of a dirty, corroded or damaged cartridge can lead to a burst cartridge case and consequent damage to the firearm and personal injury from the sudden escape of high-pressure propellant gas within the firearm's mechanism.

Immediately stop shooting and check the barrel for a possible obstruction whenever:

- You have difficulty in, or feel unusual resistance in chambering a cartridge
- A cartridge misfires (does not go off)
- The mechanism fails to extract a fired cartridge case
- Unburned grains of propellant powder are discovered spilled in the mechanism
- A shot sounds weak or abnormal

In such cases it is possible that a bullet is lodged part way down the barrel. Firing a subsequent bullet into the obstructed barrel can damage the firearm and cause serious injury to the shooter or bystanders.

Bullets can become lodged in the barrel:

- If the cartridge has been improperly loaded without propellant powder, or if the powder fails to ignite. Ignition of the cartridge primer alone will push the bullet out of the cartridge case, but usually does not generate sufficient energy to expel the bullet completely from the barrel.

➤ If the bullet is not properly seated tightly in the cartridge case. When such a cartridge is extracted from the chamber without being fired, the bullet may be left behind in the bore at the point where the rifling begins. Subsequent chambering of another cartridge may push the first bullet further into the bore.

- If there is any reason to suspect that a bullet is obstructing the barrel, immediately unload the firearm and look through the bore. It is not sufficient to merely look in the chamber. A bullet may be lodged some distance down the barrel where it cannot easily be seen. If a bullet is in the bore, do not attempt to shoot it out by using another cartridge, or by blowing it out with a blank or one from which the bullet has been removed. Such techniques can generate excessive pressure, damage the firearm and cause serious personal injury. If the bullet can be easily removed with a wood or brass dowel, (using hand pressure only, never "hammer" a bullet lodged in the bore) clean any unburned powder grains from the bore, chamber and mechanism before resuming shooting. If the bullet cannot be dislodged by tapping it with a cleaning rod, take the firearm to a gunsmith.

- Dirt, corrosion, or other foreign matter on a cartridge can impede complete chambering and may cause the cartridge case to burst upon firing. The same is true of cartridges which are damaged or deformed.

- Don't oil cartridges, and be sure to wipe the chamber clean of any oil preservative before commencing to shoot. Oil interferes with the friction between cartridge case and chamber wall that is necessary for safe functioning, and subjects the firearm to stress similar to that imposed by excessive pressure.

- Use lubricants liberally on the moving parts of your firearm. Avoid excessive spraying of any aerosol gun care product, especially where it may get on ammunition. All lubricants, and aerosol spray lubricants in particular, can penetrate cartridge primers and cause misfires. Some highly penetrative lubricants can also migrate inside cartridge cases and cause deterioration of the propellant powder; on firing, the powder may not ignite. If only the primer ignites, there is a danger that the bullet may become lodged in the barrel.

The use of reloaded or improper ammunition voids the warranty.

SPENCER MODEL – AMMUNITION WARNING

FLAT-NOSED BULLETS are the only type to be used in your Spencer, use of pointed bullets is dangerous and could result in accidental primer ignition.

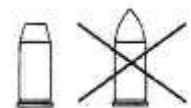

Warning: the correct functioning of this weapon is directly related to the type of ammunition employed. The total length of the ammunition should respect the indication given below with precision, because the mechanical working of this rifle is so complex and particular that it will not work with shorter or longer cartridges.

The Chiappa Firearms Spencer replica was made to reproduce exactly the functioning of the original Spencer model, and therefore reflects the original design also as far as the feeding is concerned.

Furthermore you should be careful that the lever should be opened and closed with forceful, quick movements; if you move the lever too slowly or too weakly this may cause friction and jamming.

The type of cartridge which is best suited for this rifle model is the FLAT NOSE (see picture A). This chart shows the correct cartridge length according to C.I.P. caliber standard

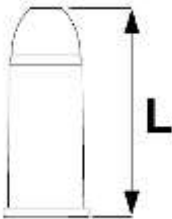
CALIBER	L in mm	L in Inches	
56/50 Spencer	38,56	1,518	
45 LC	40,64	1,600	
44/40 Win	40,44	1,592	
45 S&W Schofield	36,32	1,430	

PICTURE "A"

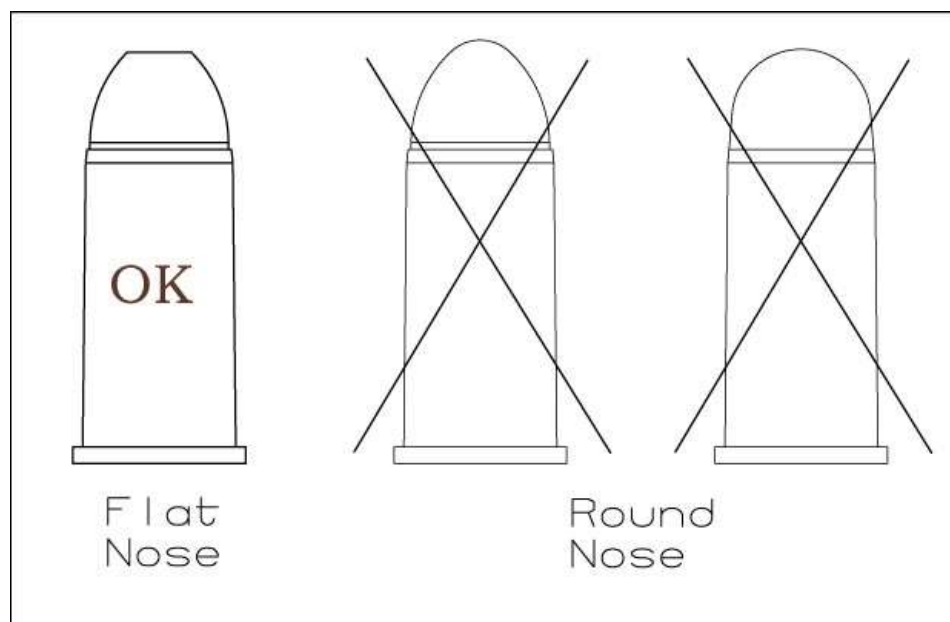

LOADING

Warning: Keep muzzle pointed in safe direction and follow all safety procedures at all times. Practice these steps with an unloaded gun or dummy ammo until you are completely familiar and comfortable with the procedures. Use live ammo only when you are prepared to shoot. Always use clean, dry, high quality ammunition (of the proper caliber) that meets industry performance standards.

1. Point de rifle in a safe direction with the muzzle pointing down.
2. Make sure the lever is in the upper position against the rifle.
3. With your thumb, press the upper end of the magazine tube base 90 degrees downward to your right and withdraw it completely from the magazine well.
4. With the exposed FLAT-NOSE BULLET pointing toward the muzzle, load the cartridges with the correct number of rounds according to the caliber.



- Remember use only **FLAT NOSED BULLETS**. You must hold the rifle at an angle so that the cartridges slide down the magazine instead of dropping in.

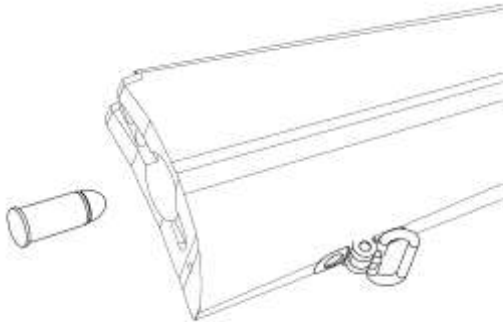

- After all rounds have been placed into the magazine well, insert the magazine tube into the magazine well until the magazine tube base is even and 90 degrees to the right of the butt plate.
- Then rotate the magazine tube base 90 degrees to your left.

FIRING

- Place your protective eyewear and ear protection on.
- Point the rifle in a safe direction.
- Move the lever to its down most position. The breechblock will then pick up a round from magazine well.
- Bring the lever back up to the up most position. The round is now chambered.
- Put your rifle to your shoulder and aim at the intended target.
- Pull the hammer back two clicks.
- Place finger on the trigger and squeeze the trigger.
- After the shot is fired, pull the lever down.
- The empty case will have been extracted and fallen to the rear.
- Pull the lever back up until the lever is all the way up and touching the rifle.
- Now a new round will have been inserted into the chamber.
- Tip: We have found that the Spencer functions best if the lever is moved briskly through its downward and upward travel without hesitation between the downward and upward strokes.

UNLOADING

- Point the rifle in a safe direction with the muzzle pointing up.
- Lower the lever to the full extent.
- With the muzzle pointed down, in a safe direction, withdraw the magazine tube, then elevate the muzzle upward and allow the unfired rounds to slide out into your hand or a soft surface.

16. Visually inspect the chamber, magazine tube and magazine for any missed rounds.
17. Replace the magazine tube.

DISASSEMBLY

1. Unload the rifle.
2. Remove the magazine tube from the magazine well. Unscrew the lever screw 13 (hinge pin) and the lever and breech block assembly out the underside of the action (receiver). Use a hollow ground screwdriver of the correct fit to avoid damage to the screw.

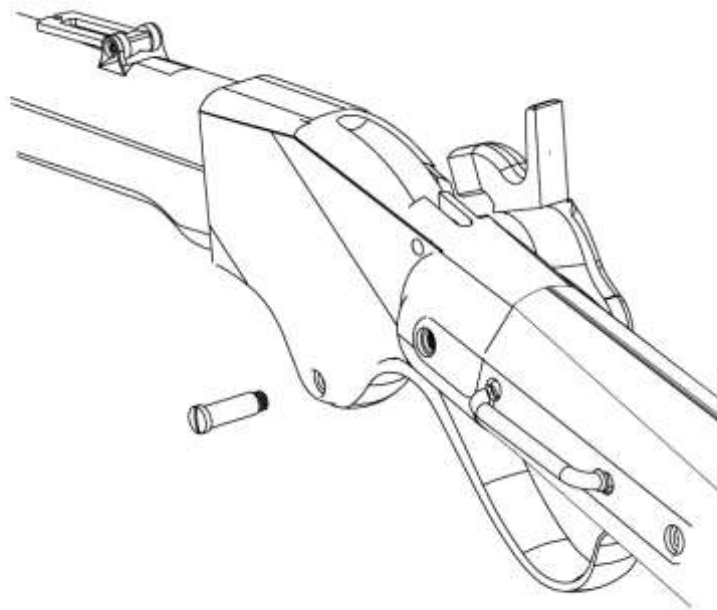

Disassembly of the breechblock:

1. Remove the block to lever screw located on the right, and separate the upper and lower breech block assemblies. The lever will slide out of the lower breech block right to left.
2. Removal of the transfer bar is done by unscrewing the transfer bar screw located on the right side of the upper breech block. The transfer bar is removed by sliding it to the right.

Disassembly of the lock plate mechanism is normally not necessary and should only be done by a competent gunsmith.

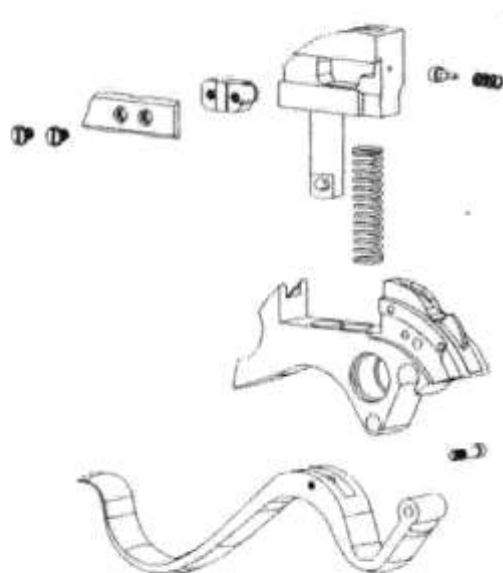

MALFUNCTION

If a cartridge hangs up, binds, jams, or fails to feed, do not force it into the chamber by pushing or striking the lever.

Most failure to feed are due to improperly loaded, damaged, or dirty ammunition, or improper rifle handling.

If a jam or failure to feed occurs, point the rifle in a safe direction and place the hammer at the half-cock position.

Point the rifle barrel towards the sky and remove the magazine tube. Allow all the rounds in the magazine well to slide out off the rifle. When the magazine well is empty, with the rifle pointed skyward, gently lower the lever and allow the stuck round to slide to the rear and out of the magazine well. Check to see if there is a round in the chamber. When the rifle has been completely unloaded, it may again be loaded in the proper procedure.

CLEANING

Attention: Careful and detailed cleaning of this firearm is essential to guarantee its safety and proper function.

This product should be cleaned after every use and when exposed to dirt, sand, etc. When not in use, clean at least twice per year. A careful and scrupulous ordinary clearing of the firearms is essential to guarantee its safety and long life. We recommend to clean the weapon at least after shooting 200 to 300 shots.

- Every time you use your gun it is advised to clean it in order to remove all corroding agents (humidity, powder or lead residues etc.) which can in time alter a few parts.
- In order to perform a standard cleaning, it is sufficient to utilize a good solvent, cleaning oil, and a little brush.
- For a deeper cleaning, please contact your local gunsmith

EXPLODED VIEW

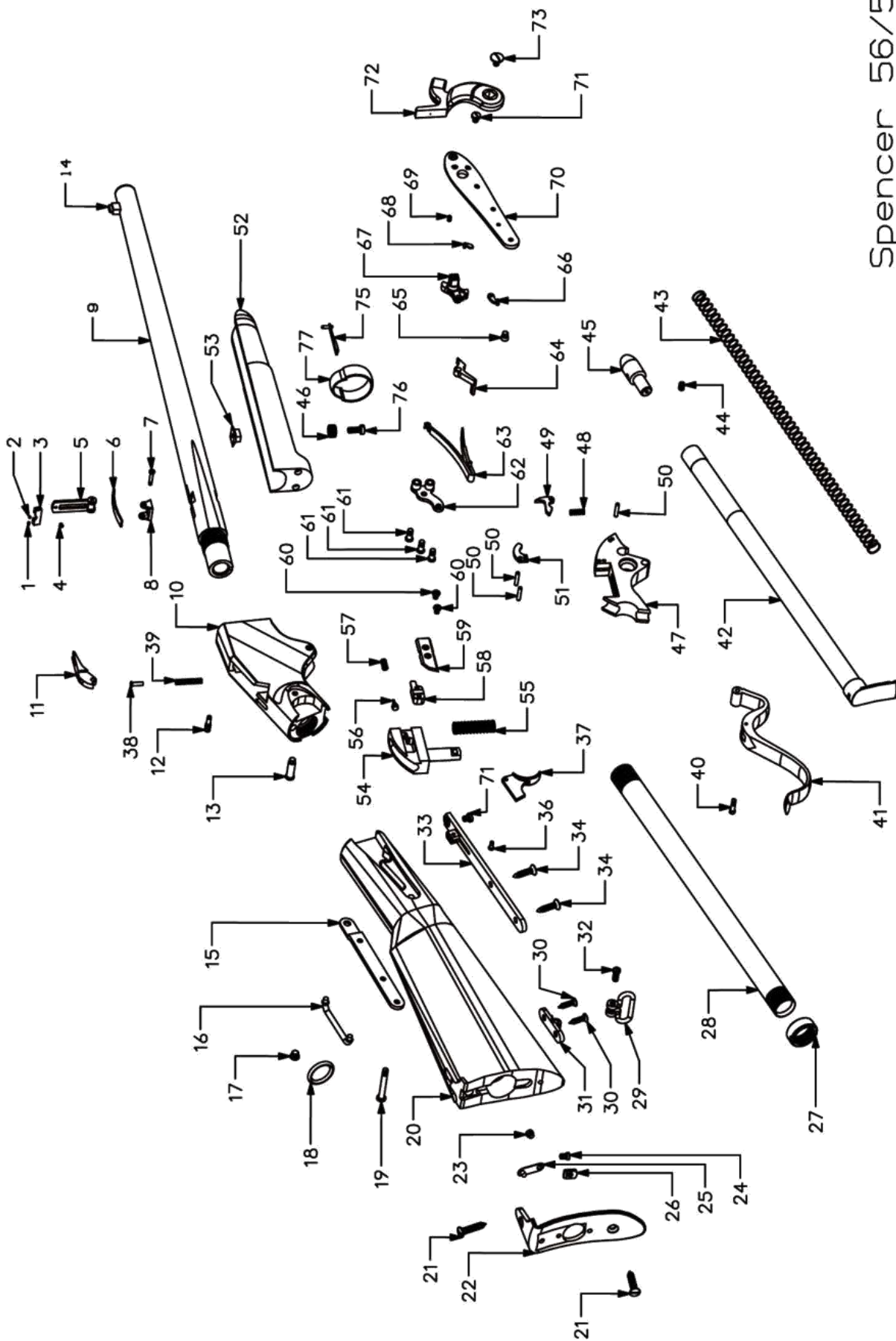

Spencer 56/50

PARTS LIST

920.021					
1865 SPENCER CARBINE .56/50					
ITEM	REF.	DESCRIPTION	ITEM	REF.	DESCRIPTION
098.155		STOCK COMPLETE	730.299	76	Forend screw
780.017	20	Stock	790.144	77	Barrel band
760.030	22	Butt plate	721.076	75	Band spring
730.247	23	Magazine catch spring screw	098.159		lower block assy
730.203	24	Magazine base catch screw	770.184	47	Lower Block
730.118	28	Magazine seat tube	770.109	51	Cam
730.119	27	Clamping tube ring	130.012	50	Cam pin
770.009	26	Magazine base catch	770.105	49	extractor
721.037	25	Magazine catch spring	720.035	48	extractor spring
730.209	21	Butt plate screw	098.160		block assy
098.156		Trigger guard assy	770.110	54	Upper block
790.138	37	Trigger	730.442	60	Percussion plate screw
790.140	33	Trigger guard	720.033	57	Firing pin spring
730.244	36	Trigger screw	730.241	56	Firing pin
098.032		Lock assy	770.012	59	Percussion plate
721.075	63	Main spring	770.011	58	Firing pin pusher
730.220	61	Bridle screw	710.056	9	barrel 56/50 carbine finished
730.219	65	Hammer spring screw	770.119	14	front sight
770.146	64	Sear	790.143	53	Barrel lug
770.081	62	Bridle	098.041		rear sight assy
790.159	72	Hammer	790.145	8	Rear sight base
770.029	70	Lock plate	730.100	7	Rear sight side screw
770.083	68	Fly	721.077	6	Rear sight base spring
730.205	73	Hammer screw	790.149	3	Rear sight slide
770.089	67	Tumbler	790.142	5	Rear sight ladder
770.082	66	Stirrup	130.021	2	Slide sphere
730.204	69	Stirrup screw	720.032	1	Slide spring
098.157			730.215	4	Rear sight slide screw
770.186	10	Receiver	098.162		forend assembly
770.202	15-16-18	saddle ring holder with ring and bridge	780.020	52	Forend
720.034	55	Block spring	730.208	46	Forend escutcheon
730.267	34	Trigger guard screw	098.141		swivel mount assy
720.068	39	Cartridge spring keeper	790.130	31	Swivel mounting plate
730.226	40	Block to lever screw	790.129	29	Swivel
730.225	12	Cartridge keeper lever screw	730.250	32	Swivel screw
730.223	17	Front saddle bar screw	730.078	30	swivel mount screw
730.221	13	Lever action screw	098.161		magazine tube assy
730.218	19	Read saddle bar screw	770.201	42	magazine tube assy
770.183	11	Cartridge keeper lever	720.029	43	magazine spring
770.027	41	Lever	730.252	45	follower
730.224	71	Front lock screw	730.232	44	magazine screw
730.436	38	cartridge keeper lever pin			

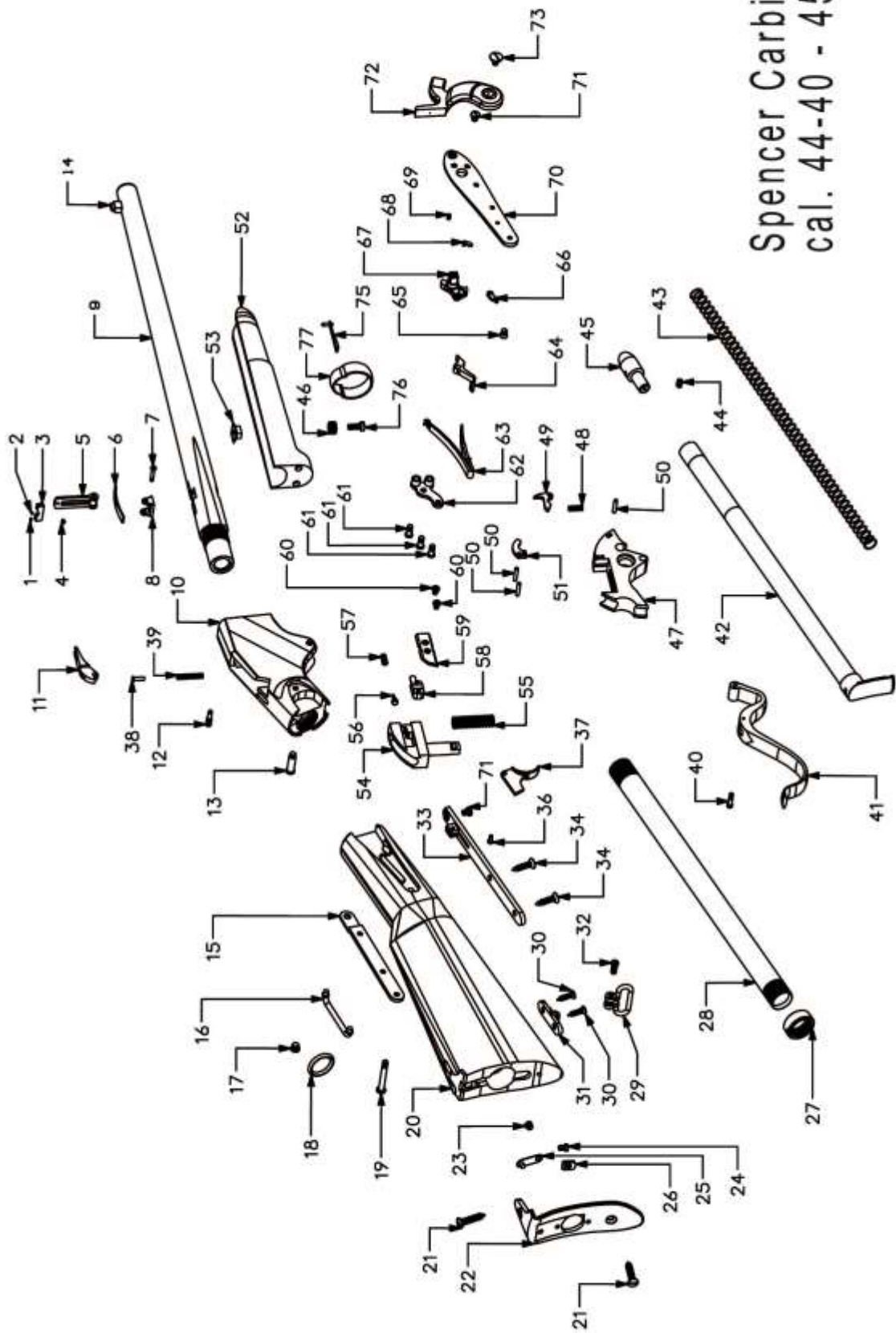

Spencer Carbine
cal. 44-40 - 45LC

920.062-084
SPENCER CARBINE 44/40 -- 45LC

ITEM	REF.	DESCRIPTION	ITEM	REF.	DESCRIPTION
098.155		STOCK COMPLETE	721.076	75	Band spring
780.017	20	Stock	098.202		lower block assy
760.030	22	Butt plate	770.184	47	Lower Block
730.247	23	Magazine catch spring screw	770.279	51	Cam
730.203	24	Magazine base catch screw	130.012	50	Cam pin
730.118	28	Magazine seat tube	770.280	49	extractor
730.119	27	Clamping tube ring	720.035	48	extractor spring
770.009	26	Magazine base catch	098.203		block assy
721.037	25	Magazine catch spring	770.281	54	Upper block
730.209	21	Butt plate screw	730.442	60	Percussion plate screw
098.156		Trigger guard assy	720.033	57	Firing pin spring
790.138	37	Trigger	730.241	56	Firing pin
790.140	33	Trigger guard	770.012	59	Percussion plate
730.244	36	Trigger screw	770.011	58	Firing pin pusher
098.032		Lock assy	710.161	9	barrel 44/40 carbine finished
721.075	63	Main spring	710.163		barrel 45 LC carbine finished
730.220	61	Bridle screw	770.119	14	front sight
730.219	65	Hammer spring screw	790.143	53	Barrel lug
770.146	64	Sear	098.041		rear sight assy
770.081	62	Bridle	790.145	8	Rear sight base
790.159	72	Hammer	730.100	7	Rear sight side screw
770.029	70	Lock plate	721.077	6	Rear sight base spring
770.083	68	Fly	790.149	3	Rear sight slide
730.205	73	Hammer screw	790.142	5	Rear sight ladder
770.089	67	Tumbler	130.021	2	Slide sphere
770.082	66	Stirrup	720.032	1	Slide spring
730.204	69	Stirrup screw	730.215	4	Rear sight slide screw
098.157			098.162		forend assembly
770.186	10	Receiver	780.020	52	Forend
770.202	15-16-18	saddle ring holder with ring and bridge	730.208	46	Forend escutcheon
720.034	55	Block spring	098.141		swivel mount assy
730.267	34	Trigger guard screw	790.130	31	Swivel mounting plate
720.068	39	Cartridge spring keeper	790.129	29	Swivel
730.226	40	Block to lever screw	730.250	32	Swivel screw
730.225	12	Cartridge keeper lever screw	730.078	30	swivel mount screw
730.223	17	Front saddle bar screw	098.209		magazine tube assy
730.221	13	Lever action screw	770.201	42	magazine tube assy
730.218	19	Rear saddle bar screw	720.029	43	magazine spring
770.183	11	Cartridge keeper lever	730.252	45	follower
770.027	41	Lever	730.232	44	magazine screw
730.224	71	Front lock screw	730.555	52	Magazine reduction
730.436	38	cartridge keeper lever pin	790.144	77	Barrel band
730.299	76	Forend screw	790.129	29	Swivel
790.144	77	Barrel band	730.250	32	Swivel screw

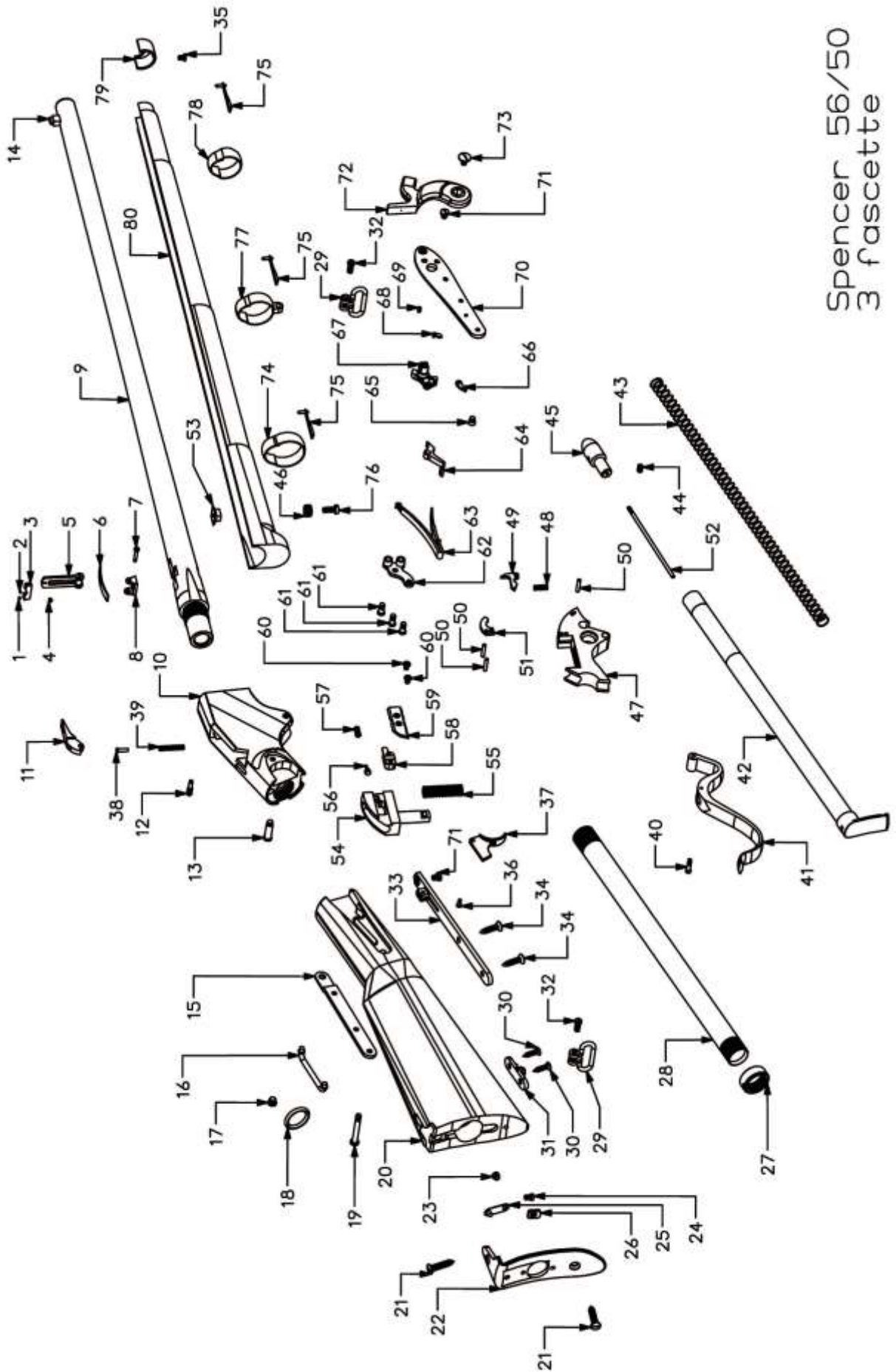

Spencer 56/50
3 fascette

920.061
SPENCER RIFLE .56/50 3 BANDS

ITEM	REF.	DESCRIPTION	ITEM	REF.	DESCRIPTION
098.155		STOCK COMPLETE	770.109	51	Cam
780.017	20	Stock	130.012	50	Cam pin
760.030	22	Butt plate	770.105	49	Extractor
730.247	23	Magazine catch spring screw	720.035	48	Extractor spring
730.203	24	Magazine base catch screw	098.160		UPPER BLOCK ASS.
730.118	28	Magazine seat tube	770.110	54	Upper block
730.119	27	Clamping tube ring	730.442	60	Percussion plate screw
770.009	26	Magazine base catch	720.033	57	Firing pin spring
721.037	25	Magazine catch spring	730.241	56	Firing pin
730.209	21	Butt plate screw	770.012	59	Percussion plate
098.156		TRIGGER GUARD ASS.	770.011	58	Firing pin pusher
790.138	37	Trigger	710.145	9	
790.140	33	Trigger guard	770.119	14	Front sight
730.244	36	Trigger screw	098.041		REAR SIGHT ASSEMBLY
098.032		LOCK COMPLETE	790.145	8	Rear sight base
721.075	63	Main spring	730.149	7	Rear sight side screw
730.220	61	Bridle screw	721.077	6	Rear sight base spring
730.219	65	Hammer spring screw	790.149	3	Rear sight slide
770.146	64	Sear	790.142	5	Rear sight ladder
770.081	62	Bridle	130.021	2	Slide sphere
790.159	72	Hammer	720.032	1	Slide spring
770.029	70	Lock plate	730.215	4	Rear sight slide screw
770.083	68	Fly	098.201		FOREND 3 BANDS ASSY
730.205	73	Hammer screw	780.051	80	forend
770.089	67	Tumbler	730.208	46	side plate screw
770.082	66	Stirrup	770.095	79	nose cap
730.204	69	Stirrup screw	730.214	35	nose cap screw
098.157			098.140		MID BARREL BAND ASS.
770.186	10	Receiver	790.127	77	barrel band middle
770.202	15-16-18	Saddle ring complete	790.129	29	swivel band
720.034	55	Block spring	730.250	32	swivel belt screw
730.267	34	Trigger guard screw	098.141		SWIVEL MOUNT PLATE ASS.
720.068	39	Cartridge spring keeper	790.130	31	Swivel mounting plate
730.226	40	Block to lever screw	790.129	29	Swivel
730.225	12	Cartridge keeper lever screw	730.250	32	Swivel screw
730.223	17	Front saddle bar screw	730.078	30	Triggerguard screw
730.221	13	Lever action screw	098.209		MAGAZINE TUBE COMPLETE
730.218	19	Read saddle bar screw	770.201	42	Magazine tube
770.183	11	Cartridge keeper lever	720.029	43	Magazine tube spring
770.027	41	Lever	730.252	45	follower cap pin
730.224	71	Front lock screw	730.232	44	Retaining screw
730.436	38		730.555	52	Magazine reduction
730.299	76	Forend screw	790.126	74	barrel band rear
790.143	53	Barrel lug	790.128	78	barrel band front
098.159		LOWER BLOCK ASS.	721.076	75	barrel band spring
770.184	47	Lower Block			

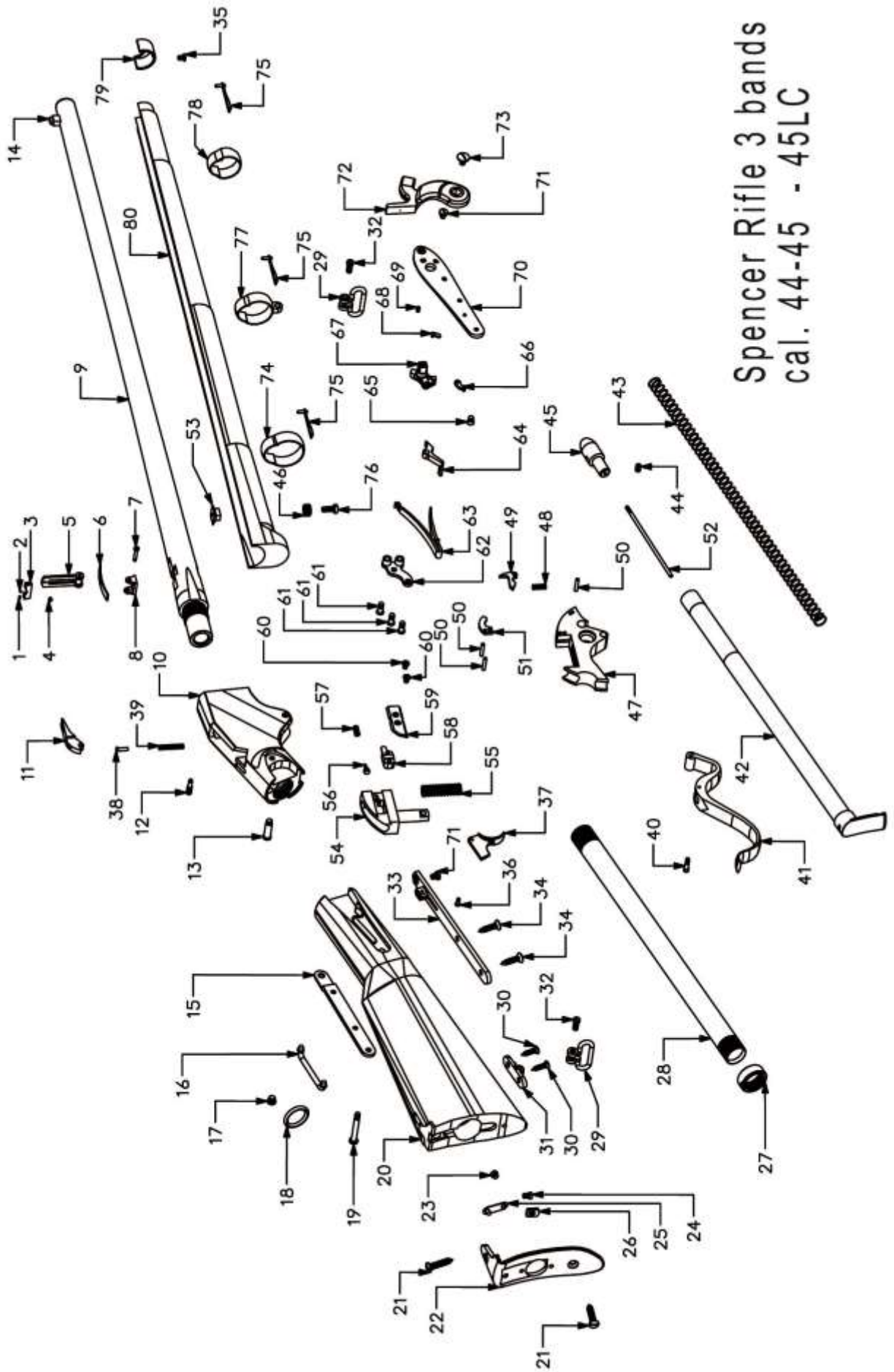

Spencer Rifle 3 bands
cal. 44-45 - 45LC

920.081-085 SPENCER RIFLE 44-40 Win - 45LC

ITEM	REF.	DESCRIPTION	ITEM	REF.	DESCRIPTION
098.155		STOCK COMPLETE	130.012	50	Cam pin
780.017	20	Stock	770.280	49	Extractor
760.030	22	Butt plate	720.035	48	Extractor spring
730.247	23	Magazine catch spring screw	098.203		UPPER BLOCK ASSEMBLY
730.203	24	Magazine base catch screw	770.281	54	Upper block
730.118	28	Magazine seat tube	730.442	60	Percussion plate screw
730.119	27	Clamping tube ring	720.033	57	Firing pin spring
770.009	26	Magazine base catch	730.241	56	Firing pin
721.037	25	Magazine catch spring	770.012	59	Percussion plate
730.209	21	Butt plate screw	770.011	58	Firing pin pusher
098.156		TRIGGER GUARD ASSY	710.162	9	Barrel 3 bands cal.44-40
790.138	37	Trigger	710.164	9	Barrel 3 bands cal.45 LC
790.140	33	Trigger guard	710.162	9	Barrel 3 bands cal.44-40
730.244	36	Trigger screw	770.119	14	Front sight
098.032		LOCK COMPLETE	098.041		REAR SIGHT ASSEMBLY
721.075	63	Main spring	790.145	8	Rear sight base
730.220	61	Bridle screw	730.149	7	Rear sight side screw
730.219	65	Hammer spring screw	721.077	6	Rear sight base spring
770.146	64	Sear	790.149	3	Rear sight slide
770.081	62	Bridle	790.142	5	Rear sight ladder
790.159	72	Hammer	130.021	2	Slide sphere
770.029	70	Lock plate	720.032	1	Slide spring
770.083	68	Fly	730.215	4	Rear sight slide screw
730.205	73	Hammer screw	098.201		FOREND 3 BANDS ASSY
770.089	67	Tumbler	780,051	80	forend 3 bands
770.082	66	Stirrup	730.208	46	side plate screw
730.204	69	Stirrup screw	770.095	79	nose cap
098.157			730.214	35	nose cap screw
770.186	10	Receiver	098.140		MIDDLE BARREL BAND ASSY
770.202	15-16-18	Saddle ring complete	790.127	77	middle barrel band
720.034	55	Block spring	790.129	29	swivel band
730.267	34	Trigger guard screw	730.250	32	swivel belt screw
720.068	39	Cartridge spring keeper	098.141		SWIVEL MOUNT PLATE ASS
730.226	40	Block to lever screw	790.130	31	Swivel mounting plate
730.225	12	Cartridge keeper lever screw	790.129	29	Swivel
730.223	17	Front saddle bar screw	730.250	32	Swivel screw
730.221	13	Lever action screw	730.078	30	Triggerguard screw
730.218	19	Read saddle bar screw	098.200		MAGAZINE TUBE COMPL
770.183	11	Cartridge keeper lever	770.201	42	Magazine tube
770.027	41	Lever	720.082	43	Magazine tube spring
730.224	71	Front lock screw	730.252	45	follower cap pin
730.436	38		730.232	44	Retaining screw
730.299	76	Forend screw	790.126	74	barrel band rear
790.143	53	Barrel lug	790.128	78	barrel band front
098.202		LOWER BLOCK ASSEMBLY	721.076	75	barrel band spring
770.184	47	Lower Block	730.555	52	Magazine reduction
770.279	51	Cam			

WARRANTY CONDITIONS

The manufacturer guarantees that our products are scrupulously checked against defects in materials, workmanship and aesthetical and functioning problems.

In case you find a defect in one of our products, you should immediately contact the DEALER/SHOP/GUNSMITH where you have bought your gun. The seller will indicate the conditions for the repair, which will be either made directly by them or through our assistance.

WARNING: end users are not allowed to ship any gun directly to the manufacturer for repair, either under guarantee or against payment. Transportation of weapons is strictly regulated and the documents which are required can solely be issued by companies with specific authorization.

The manufacturer guarantees, for a year after the purchase date, the free substitution of parts for defects which have been found out during use: wear of parts which shouldn't be subject to wear, or excessive wear of parts subject to wear. **The customer will have to give evidence of the purchase date with a bill or other valid proof.**

In case the defect under cover of guarantee is not repairable, The manufacturer will provide for a free substitution of the weapon.

THE MANUFACTURER RESERVES THE RIGHT OF DEFINING THE TYPE OF DEFECT OF THE FIREARM, AND THEREFORE TO STATE WHETHER THE DEFECT IS COVERED BY GUARANTEE. The manufacturer's decision will be fair but final.

The manufacturer will be allowed a timing of 60 days for repair under guarantee, and 180 days for free substitution.

The guarantee does not cover parts subject to wear and corrosion

ATTENTION: delivery expenses to and from the service center are not covered by the guarantee and will be charged to the customer.

This gun has been manufactured according to the regulations of Italian laws and the Italian Proof House. If exported outside Italy, the importer/distributor will be responsible to ensure that the gun complies with the local legal requirements.

THE GUARANTEE IS VOID IN CASE:

- Inadequate ammunition has been used (any ammunition but those commonly on sale, reloaded ammunition, different from caliber and specification indicated on the firearm barrel)
- The firearm failed to be provided proper maintenance and cleaning
- The firearm has been modified without our prior consent
- Unauthorized, inadequate or incorrect repairs have been carried out
- Non original spare parts were used
- Parts subject to wear and corrosion
- Damage (improper use of the gun by the user)
- Expired guarantee

In the above cases the repair, if carried out, will be charged to the customer

In case, for any valid reason, you do not have the possibility to obtain repair under guarantee at the shop where you bought the firearm, you may contact us directly; we will indicate a local dealer to support you with the repair file:

USA - Phone: +1-937-835-5000

e-mail: info@chiappafirearms.com

CANADA (Murray Charlton) – Phone +1-778.426.3884

e-mail: murray.mdcent@gmail.com

REST OF THE WORLD - Phone: +39/030/9749065

e-mail: info@chiappafirearms.com

**This instruction manual must always follow the firearm,
also in case of change of ownership**

Procedure for the use of warranty

If you have any questions, please contact the service department, at the numbers indicated above; in case you need to return the firearm for repair, please follow the instructions below:

REGISTER your firearm in our website: <http://www.chiappafirearms.com/registration>

CONTACT the gunshop where the product was bought, or the Chiappa Firearms facility for USA, Canada or Rest of the World as indicated above. You will receive a RETURN TICKET number and the shipping instructions to return the gun.

FILL IN the attached form, which will accompany the return firearm. Don't forget to include the RMA number, a description of the defect and a copy of the proof of the purchase indicating the purchase date.

SHIP the weapon to the gun shop (or to the service center) in its original packing, but first

- a) Make absolutely certain it is unloaded;
- b) Do not send ammunition with your shotgun;
- c) Remove any accessories;
- d) Please package the gun securely (be certain gun parts cannot shift during shipment) in a suitable shipping container – possibly in the original box;
- e) Include the attached form duly filling all fields, with a clear description of the problem and service you wish us to perform;
- f) Please give us a clear ship-to address, (no P.O. Box numbers) your daytime phone number and if possible a fax number and email address;
- g) Please attach a copy of the purchase proof and place your correspondence inside the package

WARNING: the returned firearm must be protected with adequate packaging; any damages occurred during transportation and handling will be the customer's responsibility

REPAIR UNDER GUARANTEE

RMA Number _____

Please write in the above box the RETURN MARCHANDISE NUMBER

1. Customer data:

- Name: _____
- Address : _____
- Town : _____
- ZIP Code : _____
- Phone : _____ Available from ____ to ____
- Fax : _____
- Email address: _____

2. Product information:

- Model : _____
- Serial number : _____

3. Gun Shop - dealer:

- Purchase date : _____
- Dealer name : _____
- Dealer address: _____

4. Description of defect:

Documents to attach: Proof of purchase with date



Via Milano 2 - 25010 Azzano Mella (BS)
Italy

www.chiappafirearms.com
email: info@chiappafirearms.com